

3.1-V to 5.5-V Input, 3-A Output, Synchronous, Step-Down Regulator with Integrated FETs

Check for Samples: [TPS51312](#)

FEATURES

- D-CAP2™ Mode Enables Fast Transient Response
- No External Compensation Required
- Input Voltage V_{IN} Range: 3.1 V to 5.5 V
- Bias Voltage V_{CC} Range: 3.1 V to 5.5 V
- Output Voltage Range: 0.6 V to 3.3 V
- 0.6-V, 1% Voltage Reference Accuracy
- Fixed Voltage Servo Soft-Start Function
- Auto-Skip, Eco-mode™ for High Efficiency at Light Loads
- Switching Frequency: 900-kHz
- UVLO, UVP, OTP and OVP Power Good Output
- Cycle-By-Cycle Current Limit, Latch-off OCP
- Thermally Enhanced 3 mm x 3 mm, 10-pin SON (DRC)

APPLICATIONS

- Battery Powered Equipment
- Notebook Computers

DESCRIPTION

The TPS51312 is a high-efficiency, synchronous, step-down DC/DC converter. It supports 3-A (maximum) of dc output current at output voltages from 0.6 V to 3.3 V. The D-CAP2 mode adaptive on-time control allows a small footprint when designed using all ceramic output capacitors and offers a low external component count. The device also features auto-skip function at light load condition, pre-biased start-up and internally fixed soft-start time. When the device is disabled, the output capacitor is discharged through internal resistor.

The TPS51312 is available in a 3 mm x 3 mm, 10-pin DRC package (Green RoHS compliant and Pb free) and is specified between -40°C and 85°C .

SIMPLIFIED APPLICATION

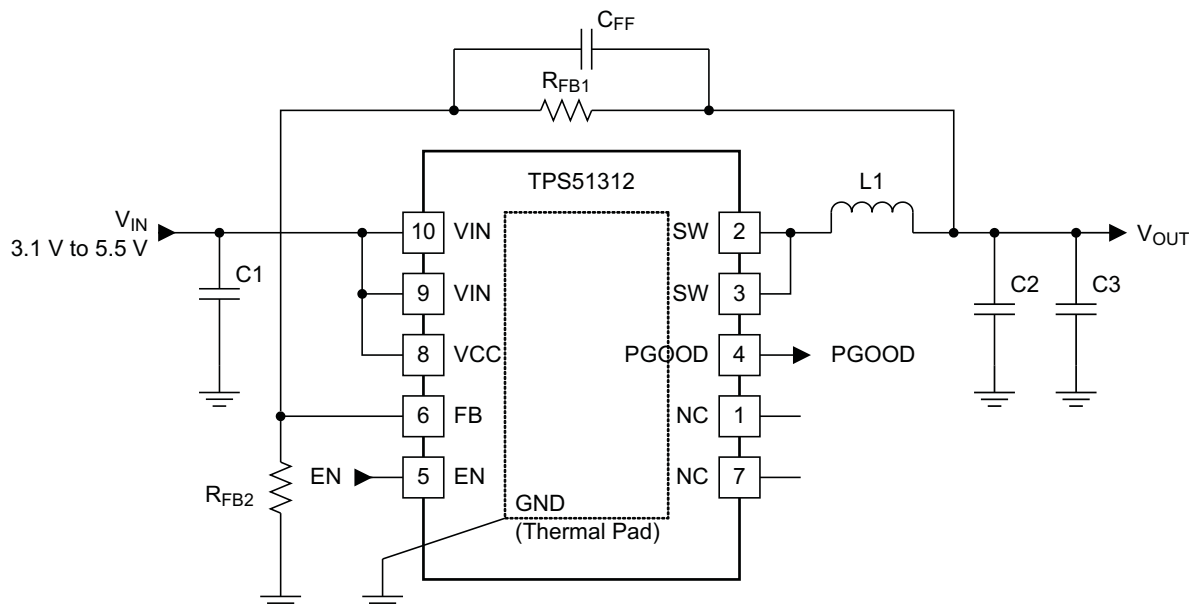

UDG-12125



Please be aware that an important notice concerning availability, standard warranty, and use in critical applications of Texas Instruments semiconductor products and disclaimers thereto appears at the end of this data sheet.

D-CAP2, Eco-mode are trademarks of Texas Instruments.
All other trademarks are the property of their respective owners.

TPS51312

SLUSB57 – SEPTEMBER 2012

www.ti.com



This integrated circuit can be damaged by ESD. Texas Instruments recommends that all integrated circuits be handled with appropriate precautions. Failure to observe proper handling and installation procedures can cause damage.

ESD damage can range from subtle performance degradation to complete device failure. Precision integrated circuits may be more susceptible to damage because very small parametric changes could cause the device not to meet its published specifications.

ORDERING INFORMATION⁽¹⁾

T _A	PACKAGE	ORDERABLE DEVICE NUMBER	PINS	OUTPUT SUPPLY	MINIMUM QUANTITY	ECO PLAN
-40°C to 85°C	Plastic SON (DRC)	TPS51312DRCR	10	Tape and reel	3000	Green (RoHS and no Pb/Br)
		TPS51312DRCT		Mini reel	250	

(1) For the most current package and ordering information see the Package Option Addendum at the end of this document, or see the TI web site at www.ti.com.

ABSOLUTE MAXIMUM RATINGS⁽¹⁾

		VALUE		UNIT
		MIN	MAX	
Input voltage range ⁽²⁾	VIN, VCC, EN	-0.3	6.0	V
	SW	-2.0	6.0	
	SW (transient 20 ns)	-3.0	8.5	
	FB	-1	3.6	
Output voltage range ⁽²⁾	PGOOD	-0.3	6.0	V
Junction temperature, T _J			125	°C
Storage temperature, T _{stg}		-55	150	°C

- (1) Stresses beyond those listed under "absolute maximum ratings" may cause permanent damage to the device. These are stress ratings only and functional operation of the device at these or any other conditions beyond those indicated under "recommended operating conditions" is not implied. Exposure to absolute-maximum-rated conditions for extended periods may affect device reliability.
- (2) All voltage values are with respect to the network ground terminal unless otherwise noted.

THERMAL INFORMATION

THERMAL METRIC ⁽¹⁾		TPS51312	UNITS
		DRC (10-PIN)	
θ _{JA}	Junction-to-ambient thermal resistance	42.4	°C/W
θ _{JCtop}	Junction-to-case (top) thermal resistance	53.9	
θ _{JB}	Junction-to-board thermal resistance	18.1	
ψ _{JT}	Junction-to-top characterization parameter	1.1	
ψ _{JB}	Junction-to-board characterization parameter	18.3	
θ _{JCbot}	Junction-to-case (bottom) thermal resistance	6.3	

(1) For more information about traditional and new thermal metrics, see the *IC Package Thermal Metrics* application report, [SPRA953](http://www.ti.com/lit/an/spra953).

RECOMMENDED OPERATING CONDITIONS

		MIN	MAX	UNIT
Input voltage range	VIN, VCC, SW, EN	-0.1	5.5	V
	FB	-0.1	3.5	
Output voltage range	PGOOD	-0.1	5.5	V
Operating free-air temperature, T _A		-40	85	°C

ELECTRICAL CHARACTERISTICS

 Over operating free-air temperature range, $V_{IN} = 5\text{ V}$, $V_{CC} = 5\text{ V}$, $V_{EN} = 3.3\text{ V}$ (unless otherwise noted).

PARAMETER		TEST CONDITION	MIN	TYP	MAX	UNIT
SUPPLY VOLTAGE						
V_{IN}	Supply voltage		3.1		5.5	V
V_{CC}	Supply voltage		3.1		5.5	V
SUPPLY CURRENT						
I_{IN}	Input voltage supply current	EN = High			100	μA
I_{SD}	Input voltage shutdown current	EN = Low			12	μA
$I_{VCC(in)}$	VCC supply current	EN = High		700		μA
$I_{VCC(sd)}$	VCC shutdown current	EN = Low, $T_A = 25^\circ\text{C}$			20	μA
VFB REFERENCE VOLTAGE						
V_{FBREF}	Reference voltage			0.6		V
$V_{FBREFTOL}$	Reference voltage tolerance	$T_A = 25^\circ\text{C}$	-1%		1%	
I_{FB}	Feedback pin leakage current		-100		100	nA
SMPS FREQUENCY						
f_{SW}	Switching frequency			0.9		MHz
$t_{OFF(min)}$	Minimum off-time		110	190	270	ns
t_{DEAD}	Dead time ⁽¹⁾	SW node high, $V_{IN} = 5\text{ V}$		9		ns
		SW node low, $V_{IN} = 5\text{ V}$		10		
LOGIC THRESHOLD AND CURRENT						
V_{LL}	EN low-level voltage				0.8	V
V_{LH}	EN high-level voltage		1.5			V
I_{LLK}	EN input leakage current	$V_{IN} = V_{CC} = 3.3\text{ V}$	-3	1	3	μA
MOSFET						
$R_{DS(on)_H}$	On-resistance ⁽¹⁾	$V_{IN} = 5\text{ V}$		81		m Ω
		$V_{IN} = 5\text{ V}$		41		
SOFT-START						
t_{SS}	Soft-start time ⁽¹⁾	V_{FB} rising from 0 V to 0.6 V		300		μs
PGOOD COMPARATOR						
V_{PGTH}	PGOOD threshold	PGOOD out to higher w/r/t V_{FB}		130%		
		PGOOD out to lower w/r/t V_{FB}		50%		
t_{PGDLY}	PGOOD high delay time	Delay for PGOOD in, after EN = Hi		1.3		ms
I_{PGLK}	PGOOD leakage current		-1	0	1	μA
PROTECTIONS						
I_{OCL}	Current limit threshold	Valley current limit, $V_{IN} = V_{CC} = 3.3\text{ V}$, $T_A = 25^\circ\text{C}$	4.8			A
V_{IN_UVLO}	VIN UVLO threshold voltage	Wake-up	2.85	2.95	3.05	V
		Shutdown	2.6	2.7	2.8	
V_{CC_UVLO}	VCC UVLO threshold voltage	Wake-up	2.85	2.95	3.05	V
		Shutdown	2.6	2.7	2.8	
V_{OVP}	OVP threshold voltage	OVP detect		130%		
t_{OVP}	OVP delay time	Overdrive = 100 mV		1.9		μs
V_{UVP}	UVP threshold voltage	UVP detect		50%		
t_{UVPDLY}	UVP delay time	Overdrive = 100 mV		2.4		μs

(1) Specified by design. Not production tested.

TPS51312

SLUSB57 – SEPTEMBER 2012

www.ti.com

ELECTRICAL CHARACTERISTICS (continued)

Over operating free-air temperature range, $V_{IN} = 5\text{ V}$, $V_{CC} = 5\text{ V}$, $V_{EN} = 3.3\text{ V}$ (unless otherwise noted).

PARAMETER	TEST CONDITION	MIN	TYP	MAX	UNIT
SW PULL-DOWN RESISTANCE					
R_{SWPD}	SW pull-down resistance	EN = Lo		260	Ω
THERMAL SHUTDOWN					
T_{SDN}	Thermal shutdown threshold ⁽²⁾	Shutdown temperature		145	$^{\circ}\text{C}$
		Hysteresis		20	

(2) Specified by design. Not production tested.

DEVICE INFORMATION FUNCTIONAL BLOCK DIAGRAM

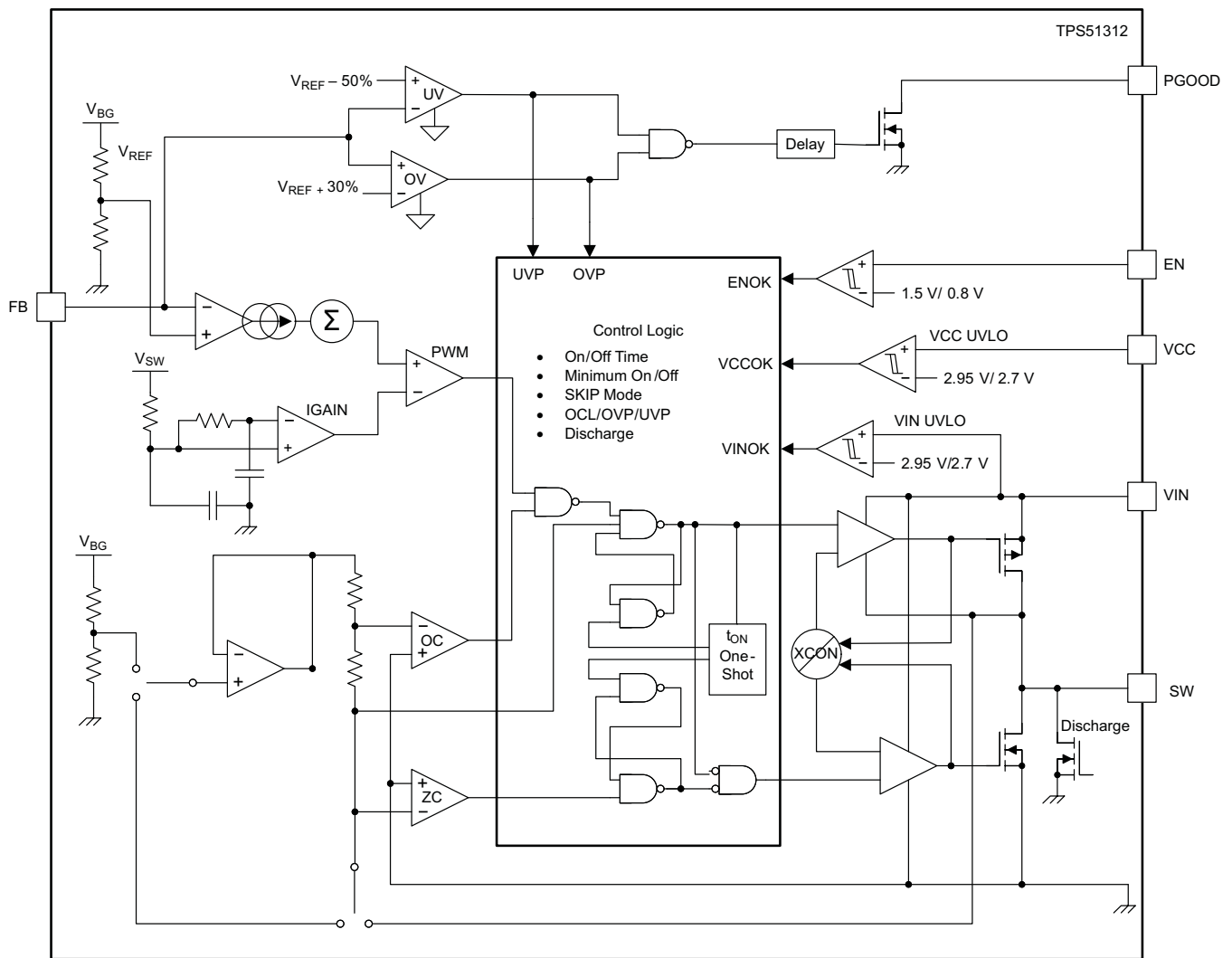

UDG-12124

**DRC PACKAGE
10 PINS
(TOP VIEW)**

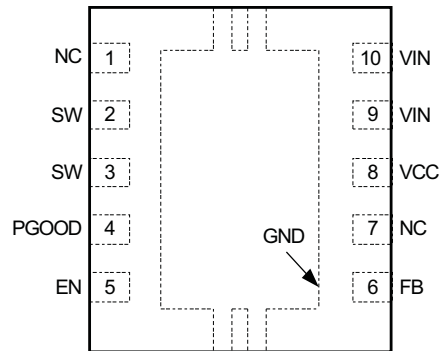

PIN FUNCTIONS

PIN		I/O	DESCRIPTION
NAME	NO.		
EN	5	I	Enable function for the switched-mode power supply (SMPS) (3.3-V logic compatible)
FB	6	I	Voltage feedback. Also used for OVP, UVP and PGOOD determination.
NC	1 7	–	No connection. Make no external connection to this pin.
PGOOD	4	O	Power good indicator. Requires external pull-up resistor.
SW	2 3	I	Switching node output. Connect to external inductor. Also serve as current sensing negative input for over current protection purpose
VCC	8	I	Power supply for analog circuit.
VIN	9 10	I	Main power conversion input and gate-drive voltage supply for output FETs.
Thermal Pad		I	Ground terminal.

TYPICAL CHARACTERISTICS

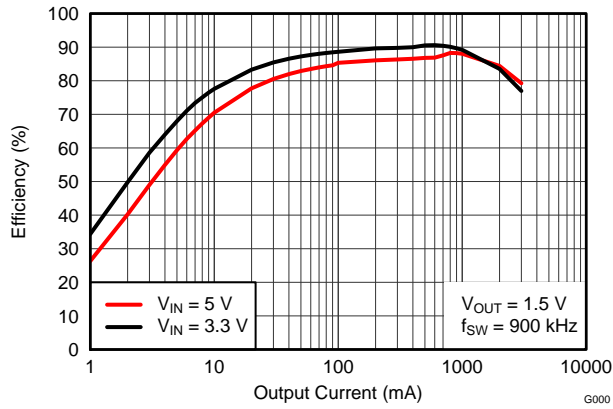

Figure 1. Efficiency vs. Output Current

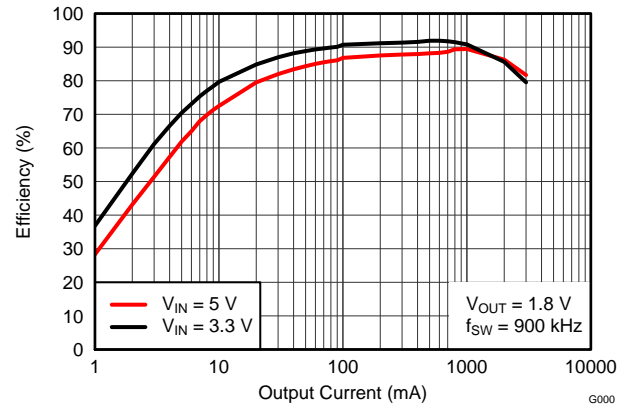

Figure 2. Efficiency vs. Output Current

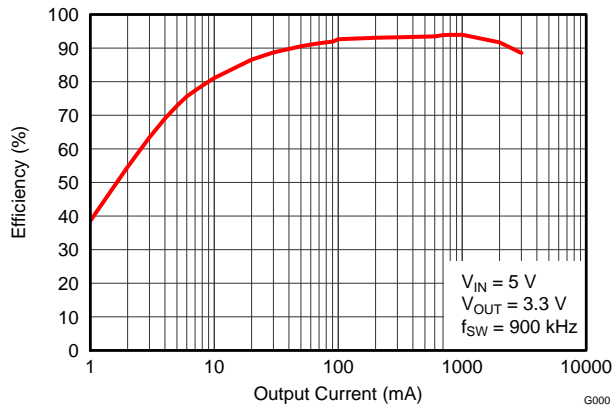

Figure 3. Efficiency vs. Output Current

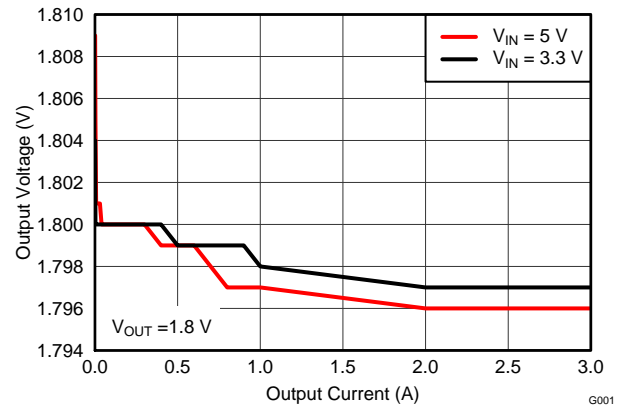

Figure 4. DC Load Regulation

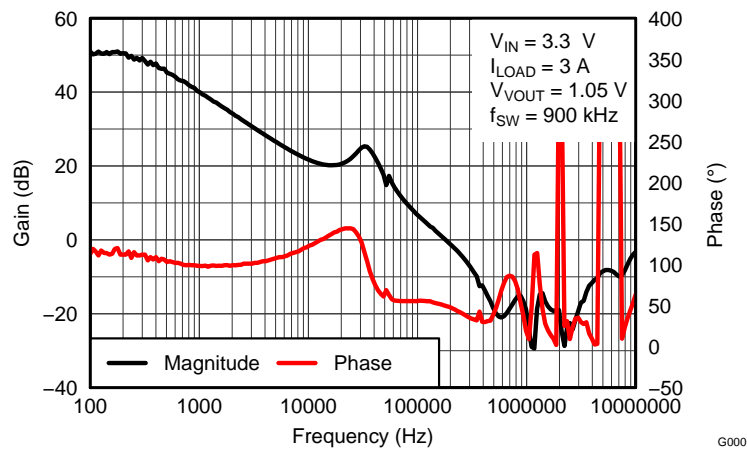

Figure 5. Bode Plot

TYPICAL CHARACTERISTICS (continued)

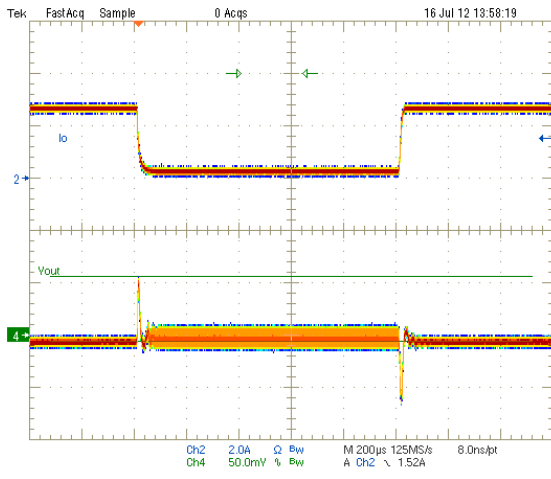

Figure 6. 3.3-V Input, 1.8-V Output from 0 A to 3 A

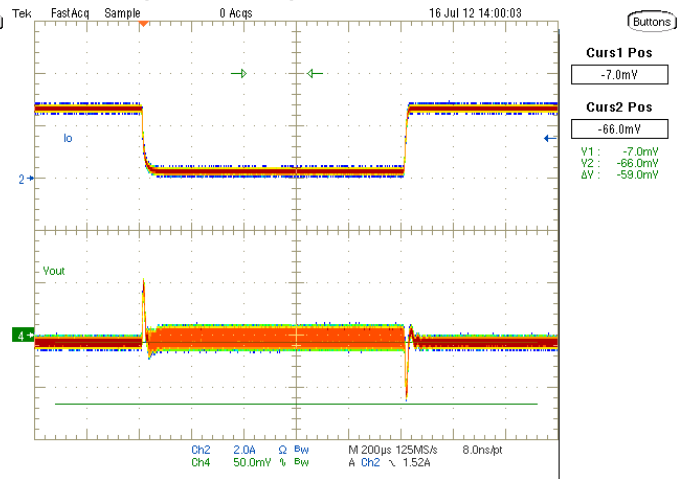

Figure 7. 5-V Input, 1.8-V Output from 0 A to 3 A

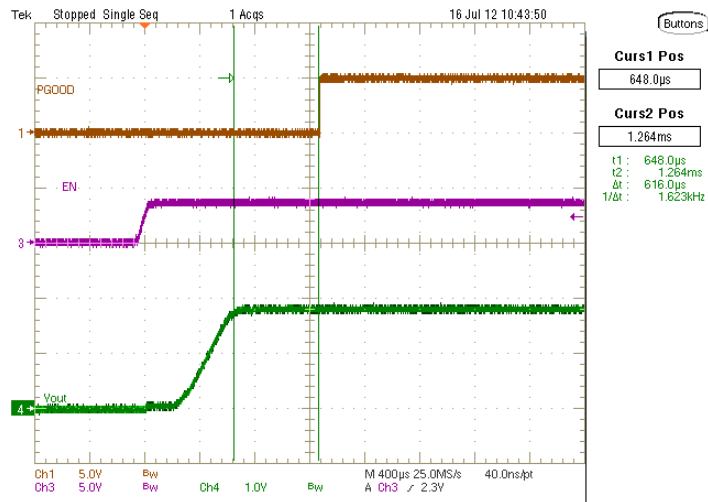

Figure 8. 5-V Input, 1.8-V Output Start-Up

APPLICATION INFORMATION

Functional Overview

TPS51312 is a D-CAP2 mode adaptive on time converter with internal integrator. Monolithically integrate high side and low side FET supports output current to a maximum of 3-ADC. The converter automatically runs in discontinuous conduction mode to optimize light load efficiency. A switching frequency of 900 kHz enables optimization of the power train for the cost, size and efficiency performance of the design.

PWM Operation

The PWM operation is comprised of three separate loops, A, B and C as shown in Figure 9.

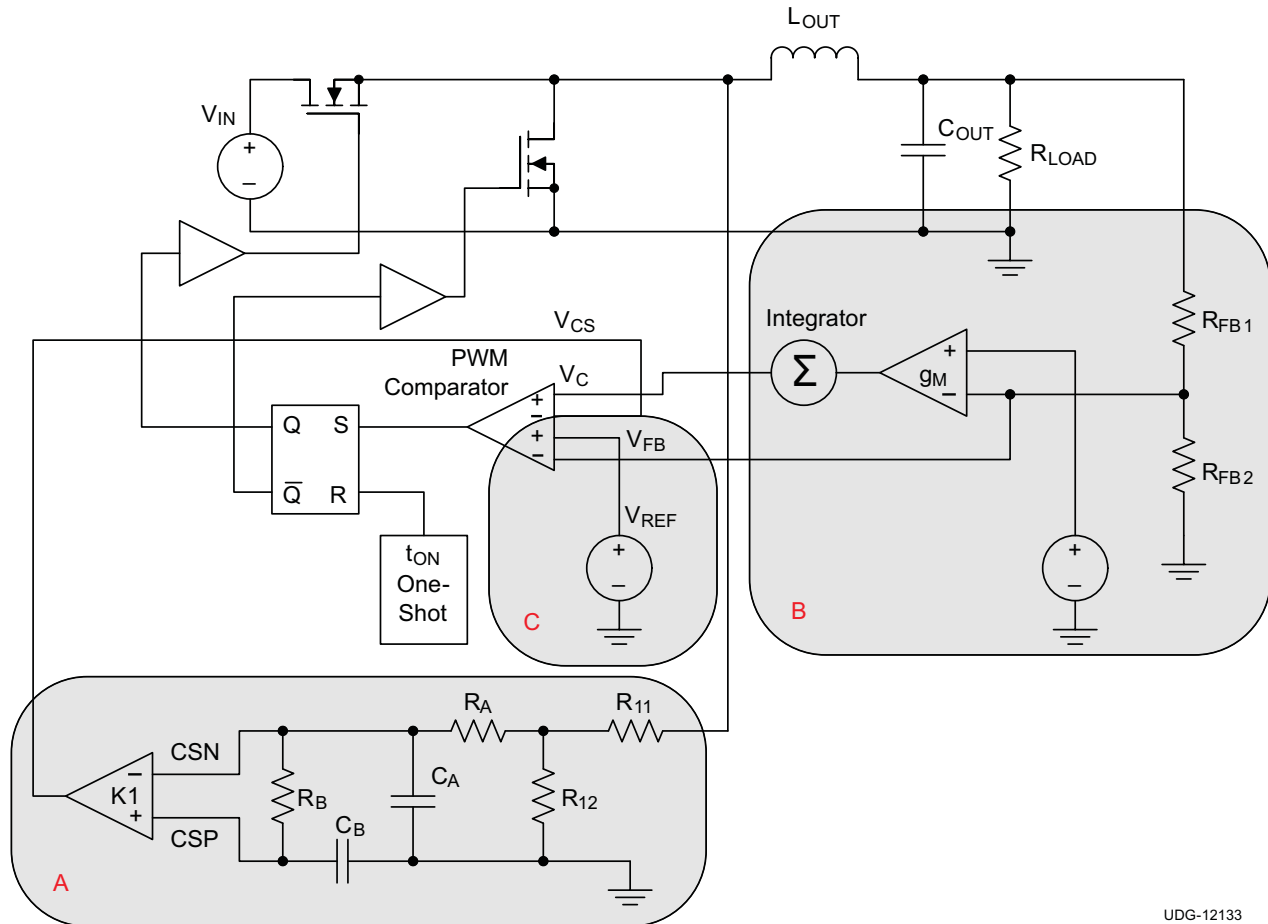

UDG-12133

Figure 9. $\frac{3}{4}$ PWM Operation

Internal Current Loop (A)

Loop A is the internal current loop. The current information is sampled, divided and averaged at the SW node. The RC time constant and the gain of the current sense amplifier is chosen to cover the wide range of power stage design intended for this application.

Internal Voltage Loop (B)

Loop B is the internal voltage loop. The feedback voltage information is compared to the voltage reference at the input of the g_M amplifier, the internal integrator is designed to provide a zero at the double pole location to boost phase margin at the desired crossover frequency.

Fast Feedforward Loop (C)

Loop C is the additional loop that acts a direct fast feedforward loop to enhance the transient response.

In steady state operation as shown in Figure 10, the on time is initiated by the interaction of the three loops mentioned above. When the $(V_C - V_{CS})$ is rising above threshold defined by $(V_{FB} - V_{REF})$, the PWM comparator issues the on time pulse after the propagation delay. The demand of on time occurs when the artificial current has reached the valley point. The load regulation is maintained by the integrator provided by the g_M amplifier and integrator.

In transient operation as shown in Figure 11, the benefit of this topology is becoming evident. In an all MLCC output configuration, especially when the output capacitance is low, when the load step is applied, the output voltage is immediately discharged to try to keep the load demand. The immediate reflection of the load demand is instantly reflected in the FB voltage. The $(V_{FB} - V_{REF})$ is thus served as a termination voltage level for the $(V_C - V_{CS})$, thus modulating the initiation of the on time. The transient response can be improved further by amplifying the difference between V_{FB} and the V_{REF} reference.

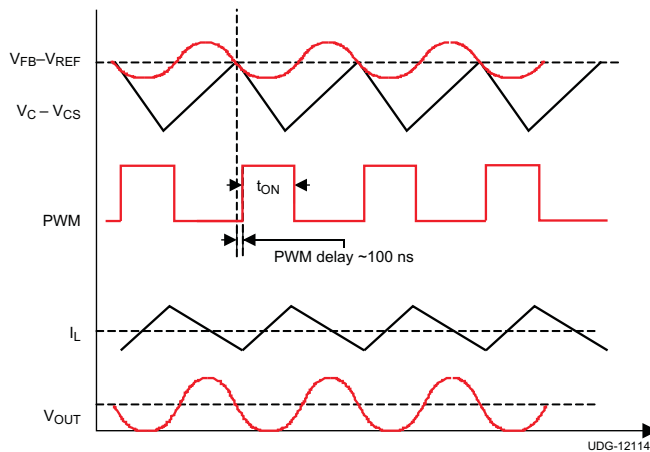

Figure 10. Steady-State Operation

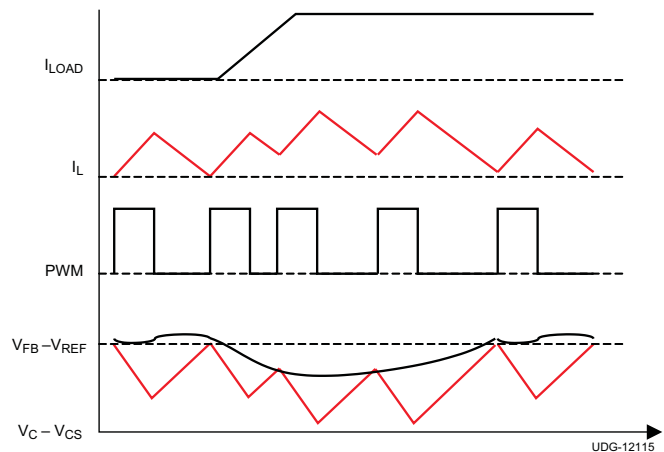

Figure 11. Transient Operation

PWM Frequency

The TPS51312 operates at a switching frequency of 900 kHz.

Light Load Power Saving Features

The TPS51312 offers an automatic pulse-skipping feature to provide excellent efficiency over the entire load range. The converter senses the current during low side FET on and prevents negative current flow by turning off the low side FET. This saves power by eliminating re-circulation of the inductor current. When the bottom FET is turned off, the converter enters discontinuous mode, and the switching frequency decreases, reducing switching loss.

Power Sequences

TPS51312 initiates the soft-start process when the EN, VIN and VCC pins are ready. The soft-start time 300 μ s when the reference voltage is between 0 V and 0.6 V (V_{REF}). The actual voltage ramp up time is the same as that of the V_{REF} start-up time, which is 300 μ s.

Power Good Signal

The TPS51312 has one open-drain power good (PGOOD) pin. During initial startup, there is a 1.3-ms power good high propagation delay after EN goes high. The PGOOD de-asserts when the EN is pulled low or an undervoltage condition on VCC or VIN or any other faults (such as V_{OUT} , UVP, OCP, OVP) that require latch off action is detected.

Protection Features

The TPS51312 offers many features to protect the converter power chain as well as the system electronics.

Input Undervoltage Protection on V_{CC} and V_{IN} (UVLO)

The TPS51312 continuously monitor the voltage on the V_{CC} and V_{IN} to ensure the voltage level is high enough to bias the converter properly and to provide sufficient gate drive potential to maintain high efficiency for the converter. The converter starts with V_{CC} and V_{IN} approximately 2.95 V and has a nominal of 250 mV of hysteresis, assuming EN is above the logic threshold level. If the UVLO level is reached for either V_{CC} or V_{IN} , the converter transitions the SW node into a tri-state and remains off until the device is reset by both V_{CC} and V_{IN} reaches 2.95 V (nominal). The PGOOD is deasserted when UVLO is detected and remains low until the device is reset.

Output Overvoltage Protection (OVP)

The TPS51312 has OVP protection circuit. An OVP event is detected when the FB voltage is approximately $130\% \times 0.6V_{REF}$. In this case, the converter de-asserts the PGOOD signal and performs the overvoltage protection function. The converter latches off both high-side and low-side FET and remains in this state after a delay of 1.9 μ s (typ) until the device is reset by EN, or V_{CC} or V_{IN} .

Output Undervoltage Protection (UVP)

Output undervoltage protection works in conjunction with the current protection described in the [Overcurrent and Current Limit Protection](#) section. If the FB voltage drops below $50\% \times 0.6 V_{REF}$, after a delay of 2.4 μ s (typ), the converter latches off. Undervoltage protection can be reset by EN, V_{CC} or V_{IN} .

Overcurrent and Current Limit Protection

The TPS51312 provides an overcurrent protection function. The nominal OCP is 4.8-A DC. When the current limit is exceeded for consecutive 9 cycles, the converter latches off and remains latched off until it is reset by EN, V_{CC} or V_{IN} .

The TPS51312 also provides current limit protection function. If the sense current is above the OCL setting, the converter delays the next on pulse until the current level drops below the OCL limit. Current limiting occurs on a pulse-by-pulse basis. During a fast or very fast overcurrent event, the output voltage tends to droop until the UVP limit is reached. Then the converter de-asserts the PGOOD signal, and latches off after a typical delay time of 2.4 μ s. The converter remains in this state until the device is reset by EN, V_{CC} or V_{IN} .

Thermal Protection

The TPS51312 has an internal temperature sensor. When the die temperature reaches a nominal of 145°C, the device shuts down until the temperature cools by approximately 20°C. Then the converter restarts. The thermal shutdown is a non-latched behavior.

REFERENCE DESIGN

Application Schematic

Figure 12 shows the application schematic..

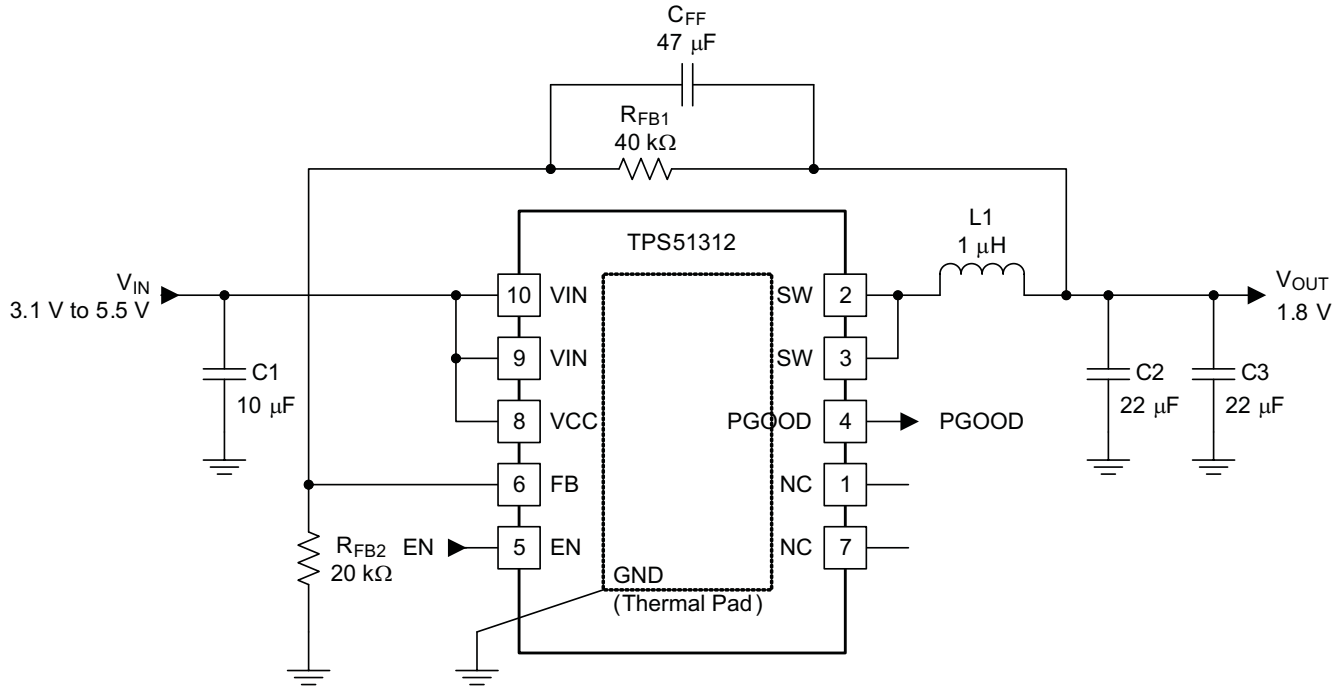

UDG-12145

Figure 12. Reference Design Schematic

Table 1. Reference Design List of Materials

FUNCTION	MANUFACTURER	PART NUMBER
Output Inductor	Vishay	IHLP-2020BZ-01
Ceramic Output Capacitors	Panasonic	ECJ2FB0J226M
	Murata	GRM21BR60J226ME39L

Design Procedure

Step One. Determine the specifications.

- $V_{OUT} = 1.8\text{ V}$
- $I_{CC(max)} = 3\text{ A}$
- $di/dt = 2.5\text{ A}/\mu\text{s}$

Step Two. Determine the system parameters.

The input voltage range and operating frequency are of primary interest. For example,

- $V_{IN} = V_{CC} = 5\text{ V}$
- $f_{SW} = 900\text{ kHz}$.

Step Three. Set the output voltage.

 Use [Equation 1](#) to determine the output voltage.

$$V_{OUT} = V_{REF} \times \left(\frac{R_{FB1} + R_{FB2}}{R_{FB2}} \right) \quad (1)$$

The output voltage is determined by VREF (0.6 V) and the resistor dividers (R_{FB1} and R_{FB2}). The output voltage is regulated to the FB pin. For the current reference design of 1.8 V, select 40 kΩ as the value for R_{FB1} and 20 kΩ as the value of R_{FB2} (see [Figure 12](#)). As a recommendation, choose a value of less 50 kΩ both resistors. Place a 47-pF, feedforward capacitor in parallel with R_{FB1} to help reduce the output voltage ripple during the transition from DCM to CCM.

Step Four. Determine inductor value and choose inductor.

Smaller inductance yields better transient performance but the consequence is higher ripple and lower efficiency. Higher values have the opposite characteristics. It is common practice to limit the ripple current to 25% to 50% of the maximum current. In this case, use 40%:

$$I_{P-P} = 3A \times 0.4 = 1.2A$$

where

- f_{SW} = 900 kHz
 - V_{IN} = 5 V
 - V_{OUT} = 1.8 V
- (2)

$$L = \frac{V \times dT}{I_{P-P}} = \left(\frac{V_{IN} - V_{OUT}}{I_{P-P}} \right) \times \left(\frac{V_{OUT}}{f_{SW} \times V_{IN}} \right) = 1\mu H \quad (3)$$

For this application, choose a 1-μH, 18.9-mΩ inductor from Vishay part number IHLP-2020BZ-01.

Step Five. Determine the output capacitance.

To determine C_{OUT} based on transient and stability requirement, first calculate the minimum output capacitance for a given transient.

[Equation 4](#) and [Equation 5](#) calculate the minimum output capacitance for meeting the transient requirement.

$$C_{OUT(min_under)} = \frac{L \times \Delta I_{LOAD(max)}^2 \times \left(\frac{V_{VOUT} \times t_{SW}}{V_{IN(min)}} + t_{MIN(off)} \right)}{2 \times \Delta V_{LOAD(insert)} \times \left(\left(\frac{V_{IN(min)} - V_{VOUT}}{V_{IN(min)}} \right) \times t_{SW} - t_{MIN(off)} \right) \times V_{VOUT}} \quad (4)$$

$$C_{OUT(min_over)} = \frac{L_{OUT} \times (\Delta I_{LOAD(max)})^2}{2 \times \Delta V_{LOAD(release)} \times V_{VOUT}} \quad (5)$$

Table 2. Choosing Output Inductors and Output Capacitors

TEMPERATURE	OUTPUT VOLTAGE V _{OUT} (V)	INDUCTANCE L _{OUT} (μH)	OUTPUT CAPACITORS		FAST FEEDFORWARD CAPACITOR C _{FF} (pF)
			NUMBER	VALUE (μF)	
-10°C ≤ T _A ≤ 85°C	1.5	1	1	22	47
	1.8	1	1		
	3.3	2.2	2		
-40°C ≤ T _A ≤ 85°C	1.5	1	2		
	1.8	1	2		
	3.3	2.2	3		

Step Six. Establishing the internal compensation loop.

The TPS51312 is designed with an internal compensation loop. The internal integrator zero location is approximately 60 kHz. During the time that the power stage double pole frequency contributed by the L_{OUT} and C_{OUT} is less than or equal to that of the zero location, the converter is stable with sufficient margin.

Step Seven. Select decoupling and peripheral components.

For TPS51312 peripheral capacitors use the following minimum value of ceramic capacitance, X5R or better temperature coefficient is recommended. Tighter tolerances and higher voltage ratings are always appropriate.

V_{CC} and V_{IN} decoupling $\geq 2 \times 10 \mu\text{F}$, 6.3 V

Pull up resistor on PGOOD = 100 k Ω

Layout Considerations

Good layout is essential for stable power supply operation. Follow these guidelines for an efficient PCB layout.

- Place V_{IN} , V_{CC} decoupling capacitors as close to the device as possible.
- Use wide traces for the VIN, SW and GND pins. These nodes carry high current and also serve as heat sinks.
- Place FB and voltage setting dividers as close to the device as possible.
- Place an R-C network from SW to GND to help to reduce the voltage spikes on the SW pin.

PACKAGING INFORMATION

Orderable Device	Status ⁽¹⁾	Package Type	Package Drawing	Pins	Package Qty	Eco Plan ⁽²⁾	Lead/ Ball Finish	MSL Peak Temp ⁽³⁾	Samples (Requires Login)
TPS51312DRCR	PREVIEW	SON	DRC	10	3000	Green (RoHS & no Sb/Br)	CU NIPDAUAG	Level-2-260C-1 YEAR	
TPS51312DRCT	PREVIEW	SON	DRC	10	250	Green (RoHS & no Sb/Br)	CU NIPDAUAG	Level-2-260C-1 YEAR	

⁽¹⁾ The marketing status values are defined as follows:

ACTIVE: Product device recommended for new designs.

LIFEBUY: TI has announced that the device will be discontinued, and a lifetime-buy period is in effect.

NRND: Not recommended for new designs. Device is in production to support existing customers, but TI does not recommend using this part in a new design.

PREVIEW: Device has been announced but is not in production. Samples may or may not be available.

OBsolete: TI has discontinued the production of the device.

⁽²⁾ Eco Plan - The planned eco-friendly classification: Pb-Free (RoHS), Pb-Free (RoHS Exempt), or Green (RoHS & no Sb/Br) - please check <http://www.ti.com/productcontent> for the latest availability information and additional product content details.

TBD: The Pb-Free/Green conversion plan has not been defined.

Pb-Free (RoHS): TI's terms "Lead-Free" or "Pb-Free" mean semiconductor products that are compatible with the current RoHS requirements for all 6 substances, including the requirement that lead not exceed 0.1% by weight in homogeneous materials. Where designed to be soldered at high temperatures, TI Pb-Free products are suitable for use in specified lead-free processes.

Pb-Free (RoHS Exempt): This component has a RoHS exemption for either 1) lead-based flip-chip solder bumps used between the die and package, or 2) lead-based die adhesive used between the die and leadframe. The component is otherwise considered Pb-Free (RoHS compatible) as defined above.

Green (RoHS & no Sb/Br): TI defines "Green" to mean Pb-Free (RoHS compatible), and free of Bromine (Br) and Antimony (Sb) based flame retardants (Br or Sb do not exceed 0.1% by weight in homogeneous material)

⁽³⁾ MSL, Peak Temp. -- The Moisture Sensitivity Level rating according to the JEDEC industry standard classifications, and peak solder temperature.

Important Information and Disclaimer: The information provided on this page represents TI's knowledge and belief as of the date that it is provided. TI bases its knowledge and belief on information provided by third parties, and makes no representation or warranty as to the accuracy of such information. Efforts are underway to better integrate information from third parties. TI has taken and continues to take reasonable steps to provide representative and accurate information but may not have conducted destructive testing or chemical analysis on incoming materials and chemicals. TI and TI suppliers consider certain information to be proprietary, and thus CAS numbers and other limited information may not be available for release.

In no event shall TI's liability arising out of such information exceed the total purchase price of the TI part(s) at issue in this document sold by TI to Customer on an annual basis.

DRC (S-PVSON-N10)

PLASTIC SMALL OUTLINE NO-LEAD

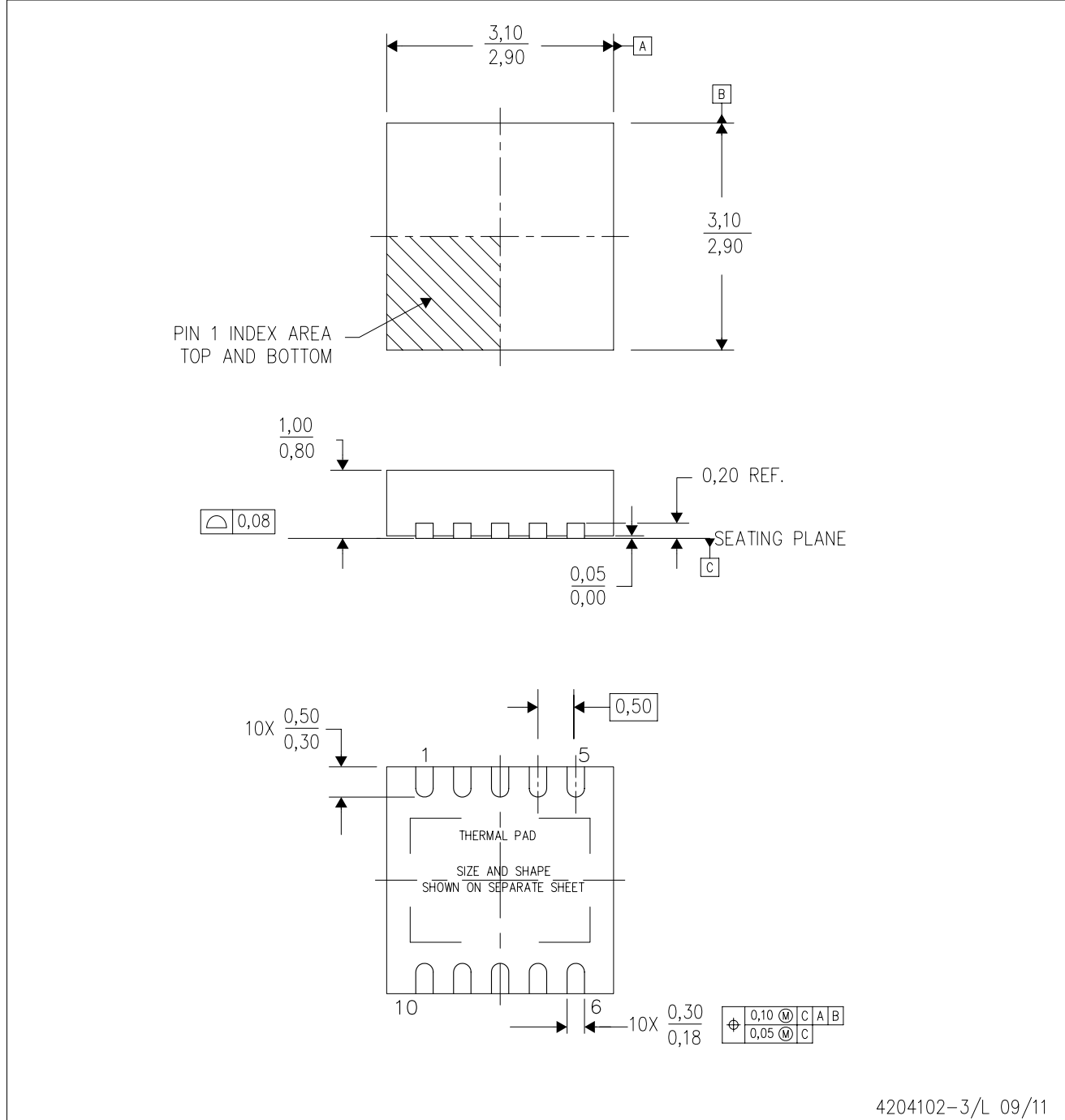

- NOTES:
- All linear dimensions are in millimeters. Dimensioning and tolerancing per ASME Y14.5M-1994.
 - This drawing is subject to change without notice.
 - Small Outline No-Lead (SON) package configuration.
 - The package thermal pad must be soldered to the board for thermal and mechanical performance, if present.
 - See the additional figure in the Product Data Sheet for details regarding the exposed thermal pad features and dimensions, if present

IMPORTANT NOTICE

Texas Instruments Incorporated and its subsidiaries (TI) reserve the right to make corrections, enhancements, improvements and other changes to its semiconductor products and services per JESD46, latest issue, and to discontinue any product or service per JESD48, latest issue. Buyers should obtain the latest relevant information before placing orders and should verify that such information is current and complete. All semiconductor products (also referred to herein as "components") are sold subject to TI's terms and conditions of sale supplied at the time of order acknowledgment.

TI warrants performance of its components to the specifications applicable at the time of sale, in accordance with the warranty in TI's terms and conditions of sale of semiconductor products. Testing and other quality control techniques are used to the extent TI deems necessary to support this warranty. Except where mandated by applicable law, testing of all parameters of each component is not necessarily performed.

TI assumes no liability for applications assistance or the design of Buyers' products. Buyers are responsible for their products and applications using TI components. To minimize the risks associated with Buyers' products and applications, Buyers should provide adequate design and operating safeguards.

TI does not warrant or represent that any license, either express or implied, is granted under any patent right, copyright, mask work right, or other intellectual property right relating to any combination, machine, or process in which TI components or services are used. Information published by TI regarding third-party products or services does not constitute a license to use such products or services or a warranty or endorsement thereof. Use of such information may require a license from a third party under the patents or other intellectual property of the third party, or a license from TI under the patents or other intellectual property of TI.

Reproduction of significant portions of TI information in TI data books or data sheets is permissible only if reproduction is without alteration and is accompanied by all associated warranties, conditions, limitations, and notices. TI is not responsible or liable for such altered documentation. Information of third parties may be subject to additional restrictions.

Resale of TI components or services with statements different from or beyond the parameters stated by TI for that component or service voids all express and any implied warranties for the associated TI component or service and is an unfair and deceptive business practice. TI is not responsible or liable for any such statements.

Buyer acknowledges and agrees that it is solely responsible for compliance with all legal, regulatory and safety-related requirements concerning its products, and any use of TI components in its applications, notwithstanding any applications-related information or support that may be provided by TI. Buyer represents and agrees that it has all the necessary expertise to create and implement safeguards which anticipate dangerous consequences of failures, monitor failures and their consequences, lessen the likelihood of failures that might cause harm and take appropriate remedial actions. Buyer will fully indemnify TI and its representatives against any damages arising out of the use of any TI components in safety-critical applications.

In some cases, TI components may be promoted specifically to facilitate safety-related applications. With such components, TI's goal is to help enable customers to design and create their own end-product solutions that meet applicable functional safety standards and requirements. Nonetheless, such components are subject to these terms.

No TI components are authorized for use in FDA Class III (or similar life-critical medical equipment) unless authorized officers of the parties have executed a special agreement specifically governing such use.

Only those TI components which TI has specifically designated as military grade or "enhanced plastic" are designed and intended for use in military/aerospace applications or environments. Buyer acknowledges and agrees that any military or aerospace use of TI components which have **not** been so designated is solely at the Buyer's risk, and that Buyer is solely responsible for compliance with all legal and regulatory requirements in connection with such use.

TI has specifically designated certain components which meet ISO/TS16949 requirements, mainly for automotive use. Components which have not been so designated are neither designed nor intended for automotive use; and TI will not be responsible for any failure of such components to meet such requirements.

Products

Audio	www.ti.com/audio
Amplifiers	amplifier.ti.com
Data Converters	dataconverter.ti.com
DLP® Products	www.dlp.com
DSP	dsp.ti.com
Clocks and Timers	www.ti.com/clocks
Interface	interface.ti.com
Logic	logic.ti.com
Power Mgmt	power.ti.com
Microcontrollers	microcontroller.ti.com
RFID	www.ti-rfid.com
OMAP Applications Processors	www.ti.com/omap
Wireless Connectivity	www.ti.com/wirelessconnectivity

Applications

Automotive and Transportation	www.ti.com/automotive
Communications and Telecom	www.ti.com/communications
Computers and Peripherals	www.ti.com/computers
Consumer Electronics	www.ti.com/consumer-apps
Energy and Lighting	www.ti.com/energy
Industrial	www.ti.com/industrial
Medical	www.ti.com/medical
Security	www.ti.com/security
Space, Avionics and Defense	www.ti.com/space-avionics-defense
Video and Imaging	www.ti.com/video

TI E2E Community

e2e.ti.com